



Hoist Installation and Operation Instructions



Pacific Rim International, LLC
19120 SE 34th Street., Suite 105
Vancouver, WA 98683
Phone: 360-859-3828



RH-310 Hoist Assembly 310 (310 hoist plus installation pivot bars)
RH-516 Hoist Assembly 516 (516 hoist plus installation pivot bars)
RH-520 Hoist Assembly 520 (520 hoist plus installation pivot bars)
RH-620 Hoist Assembly 620 (620 hoist plus installation pivot bars)

See end of instructions for all other accessory items available that are sold separately

RAM hoists and cylinder hoists sold separately and are designed for dump trailer applications only.

Always load and unload trailer when attached to the tow vehicle.

Pacific Rim International/Pacific Trailer Products is not responsible for damages as a result of improper use, installation and care for product.

It is the end users responsibility to determine trailer support member and welding size to properly support the load being lifted. Illustrations are for instructional purposes only.

Make sure trailer builder has included all proper warning instructions they should be providing as a manufacturer.

Never overload a trailer beyond the gross vehicle weight rating (GVW) or gross axle weight rating (GAW) of the trailer or vehicle.

Make sure to follow the instructions carefully that the trailer manufacturer provides with the trailer.

Make sure brake lines, electrical wiring, hydraulic lines, etc do not interfere with the operation of the hoist system. If the hoist system is allowed to rub against those items mentioned could result in damage and therefor an unsafe trailer.

Always use caution while working around hydraulic systems. Make sure to stay away while welding not to ignite fluids which could cause serious injury.

Always install equipment to keep heat from exhaust system away from the hydraulic systems as it could damage components.

Never attempt to jerk or shock the trailer with the dump in a raised position to remove a stuck load. This could cause damage which could cause serious injury.

Maximum pump load to not exceed 3200 psi.

Safety Arm Installation And Use

Always support an unloaded dump trailer body with the safety arm. The safety arm is for supporting an unloaded dump trailer body only.

Never position yourself or others under a loaded dump trailer body as it could result in serious injury or death.

Safety arm use:

- Raise dump trailer body to a sufficient height and shut off the hydraulic power to the cylinder hoist.
- Take safety arm out of the safety arm bracket and rotate up into a vertical position below the safety arm cup.
- Slowly lower the cylinder hoist until the top of the safety arm is seated into the safety arm cup
- To remove the safety arm, reverse this process and place the safety arm back into the safety arm bracket.

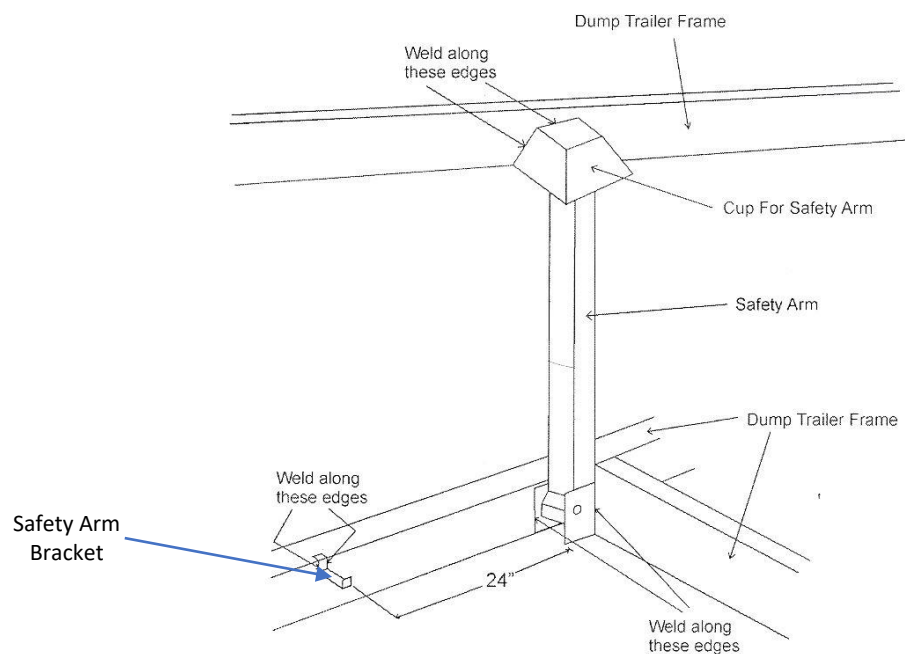

Max Unloaded Tilt Body Weight in lbs using one safety arm

Tilt Body Trailer Length In Feet

| | 8 | 10 | 12 | 14 | 16 | 18 | 20 |
|-----|------|------|------|------|------|------|------|
| 50 | 3854 | 3083 | 2569 | 2202 | 1927 | 1713 | 1542 |
| 60 | 4625 | 3700 | 3083 | 2643 | 2313 | 2056 | 1850 |
| 70 | 5396 | 4317 | 3597 | 3083 | 2698 | 2398 | 2158 |
| 80 | 6167 | 4933 | 4111 | 3524 | 3083 | 2741 | 2467 |
| 90 | 6938 | 5550 | 4625 | 3964 | 3469 | 3083 | 2775 |
| 100 | | 6167 | 5139 | 4405 | 3854 | 3426 | 3083 |
| 110 | | 6783 | 5653 | 4845 | 4240 | 3769 | 3392 |
| 120 | | 7400 | 6167 | 5286 | 4625 | 4111 | 3700 |
| 130 | | | 6681 | 5726 | 5010 | 4454 | 4008 |
| 140 | | | 7194 | 6167 | 5396 | 4796 | 4317 |
| 150 | | | | 6607 | 5781 | 5139 | 4625 |
| 160 | | | | 7048 | 6167 | 5481 | 4933 |
| 170 | | | | | 6552 | 5824 | 5242 |
| 180 | | | | | 6938 | 6167 | 5550 |
| 190 | | | | | 7323 | 6509 | 5858 |
| 200 | | | | | | 6852 | 6167 |
| 210 | | | | | | 7194 | 6475 |
| 220 | | | | | | | 6783 |
| 230 | | | | | | | 7092 |

Distance from rear hinge to safety arm in inches

Hoist Welding and Placement

When welding hoist brackets in place weld on all contact surfaces.

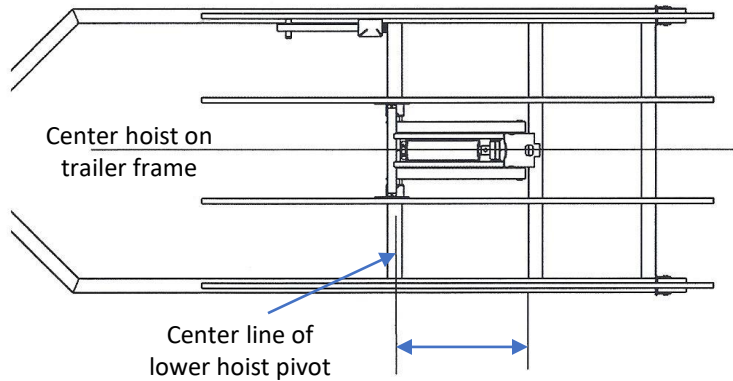
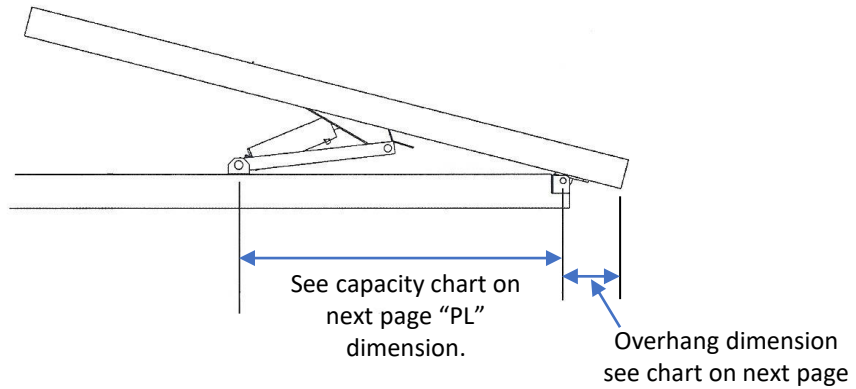

Locking Collar

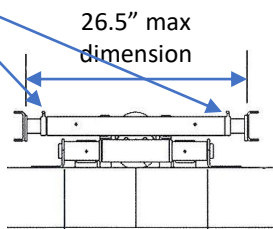

- 310 hoist = 27"
- 516 hoist = 38"
- 520 hoist = 46"
- 620 hoist = 46"

Weight Capacities

Hoist Capacity In Tons

| Dump Compartment Body Length (ft) | Overhang (ft) | RH-310 | RH-310 | RH-516 | RH-516 | RH-520 | RH-520 | RH-620 | RH-620 |
|---|------------------|-----------------------------------|-----------------------------------|-----------------------------------|-------------------------------------|--------------------------------------|--------------------------------------|--------------------------------------|--------------------------------------|
| | | Max Angle 45 degrees PL=52" | Max Angle 50 degrees PL=47" | Max Angle 45 degrees PL=76" | Max Angle 50 degrees PL=67.5" | Max Angle 45 degrees PL=96.75" | Max Angle 50 degrees PL=87.75" | Max Angle 45 degrees PL=96.75" | Max Angle 50 degrees PL=87.75" |
| 8 | 1 | 3.8 | 3.4 | | | | | | |
| 8 | 1.5 | 4.5 | 4.0 | | | | | | |
| 8 | 2 | 5.6 | 5.0 | | | | | | |
| 9 | 1 | 3.1 | 2.9 | | | | | | |
| 9 | 1.5 | 3.8 | 3.4 | | | | | | |
| 9 | 2 | 4.5 | 4.1 | | | | | | |
| 10 | 1 | 2.9 | 2.4 | 9.7 | 8.6 | 12.4 | 11.2 | 15.5 | 14 |
| 10 | 1.5 | 3.2 | 2.9 | 11.1 | 9.8 | 14.1 | 12.8 | 17.7 | 16.0 |
| 10 | 2 | 3.8 | 3.4 | 12.9 | 11.5 | 16.5 | 14.9 | 20.6 | 18.6 |
| 12 | 1 | | | 7.8 | 6.9 | 9.9 | 9.0 | 12.4 | 11.2 |
| 12 | 1.5 | | | 8.6 | 7.7 | 11.0 | 9.9 | 13.7 | 12.4 |
| 12 | 2 | | | 9.7 | 8.6 | 12.4 | 11.2 | 15.5 | 14 |
| 14 | 1 | | | 6.5 | 5.7 | 8.2 | 7.5 | 10.3 | 9.3 |
| 14 | 1.5 | | | 7.0 | 6.3 | 9.0 | 8.1 | 11.2 | 10.2 |
| 14 | 2 | | | 7.8 | 6.9 | 9.9 | 9.0 | 12.4 | 11.2 |
| 16 | 1 | | | | | 7.1 | 6.4 | 8.8 | 8.0 |
| 16 | 1.5 | | | | | 7.6 | 6.9 | 9.5 | 8.6 |
| 16 | 2 | | | | | 8.2 | 7.5 | 10.3 | 9.3 |

All information above is a general guide. It is trailer manufacturer's responsibility as to overall capacities for a specific trailer design. These calculations are also based on a level/evenly dispersed load.

Cylinder Installation

After trailer with hoist frame is painted or powder coated, bolt into place hydraulic cylinder (hardware not included).

Lubricate the all joints/grease zerks with extreme pressure grease every six months.

Hydraulic Hose Attachment

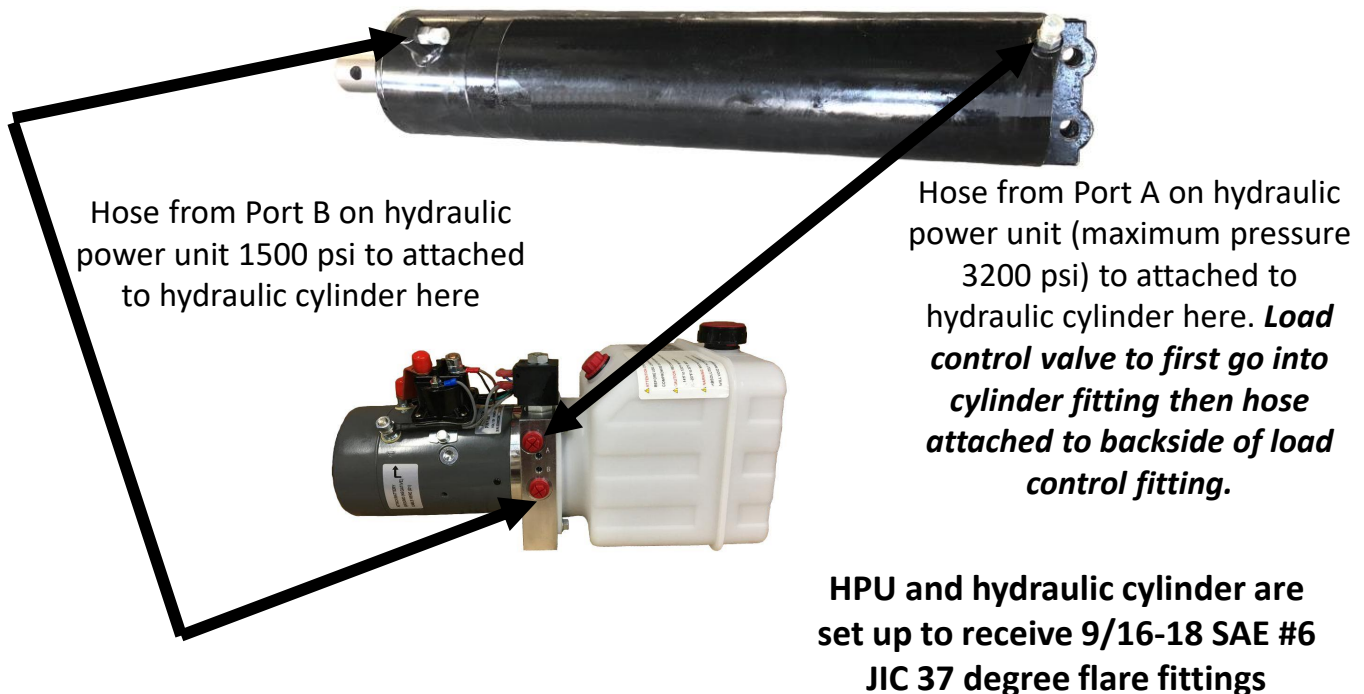

For hydraulic hose hook up to hydraulic power unit and air bleeding, refer to HPU instructions

Troubleshooting

If hoist is not extending or retracting check the following:

- Make sure all electrical connections are secure and battery is fully charged and grounded.
- Make sure hydraulic fluid is flowing from the HPU unit and through the lines. Check to make sure there are no leaks or pinch points in the hoses and all hydraulic connections are secure.
- If jack retracts after leveled to desired location, check fluid level in the HPU unit and all connections are secure.

HPU / Control Switch – Remote Pendant



- Hydraulic power unit includes control switch / remote pendant (sold separately from RAM 15K Jack HJ-15000-LEG)
- 3200 psi extension / 1500 psi retraction maximum pressure
- Works with RAM 15K hydraulic jack (HJ-15000-LEG) as well as RAM hydraulic dump trailer hoist systems (RH-310, RH-516, RH-520 and RH-620)
- HPU-DA004 dual acting, four quarts usable volume
- HPU-DA006 dual acting, six quarts usable volume
- HPU-DA008 dual acting, eight quarts usable volume

If using *RAM* supplied HPU units and control switch / remote pendant see those instructions for setup and operation.

If using another supplier's HPU unit and control switch / remote pendant see their instructions for setup and operation.

Other Hydraulic Accessories Available - Continued (sold separately)



RH-FIT38 3/8" fitting



RH-FIT38L 3/8" L-
shape fitting



RH-LDCTL 3/8" load control valve



HFD-612 Flow
Divider



RH-LHG Heavy duty hinge
assembly



RH-MHG Medium duty
hinge assembly



RH-LKCL-20 2" locking collar
RH-LKCL-25 2.5" locking collar
RH-LKCL-275 2.75" locking collar



RH-BCBL-20G4 Battery cables,
one red, one black, GA 4 20"



RH-STRP rubber
battery strap



HCYLND-516 5" diameter x 16" stroke hydraulic cylinder
HCYLND-520 5" diameter x 20" stroke hydraulic cylinder
HCYLND-620 6" diameter x 20" stroke hydraulic cylinder



Dump Trailer Hoist with weld on brackets/pivot bars (less hydraulic cylinder)

RH-310 Hoist Assembly 310 (set up for 3" diameter and 10" stroke cylinder)
RH-516 Hoist Assembly 516 (set up for 5" diameter and 16" stroke cylinder)
RH-520 Hoist Assembly 520 (set up for 5" diameter and 20" stroke cylinder)
RH-620 Hoist Assembly 620 (set up for 6" diameter and 20" stroke cylinder)

Hydraulic Hoist Safety Accessories



Safety arm

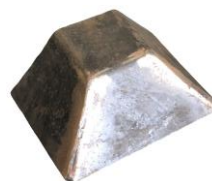

Safety arm cup



Safety arm bracket