



Hydraulic Jack Installation and Operation Instructions



HJ-15000-LEG1 hydraulic ports on top to right shown above with mounting brackets
HJ-15000-LEG2 hydraulic ports on top to left with mounting brackets also available
HJ-15070-LEG1 and HJ-15070-LEG2 with built in patent pending counter balance also available



HJ-15000-LEG direct weld model (Ports on top to right as shown. Can be turned 180 degrees and direct welded also)
HJ-15070-LEG with built in patent pending counter balance also available

Pacific Rim International, LLC
19120 SE 34th Street., Suite 105
Vancouver, WA 98683
Phone: 360-859-3828

RAM hydraulic jacks are for trailer applications only. They are designed for maximum support of 15,000lb (per leg) and lift capacity of 12,000lb (per leg).

Always load trailer when attached to the tow vehicle.

Pacific Rim International/Pacific Trailer Products is not responsible for damages as a result of improper use, installation and care for product.

Maximum pump load to not exceed 3200 psi.

Bolt to trailer frame using the mounting bracket locations as it works for your specific application (hardware not included). (For direct weld applications follow ASTM for welding to carbon and low alloy steel tubes. Weld per specific application. Weld however should not be closer than 1" from the top of the outer tube nor 1" from the bottom of the outer tube.

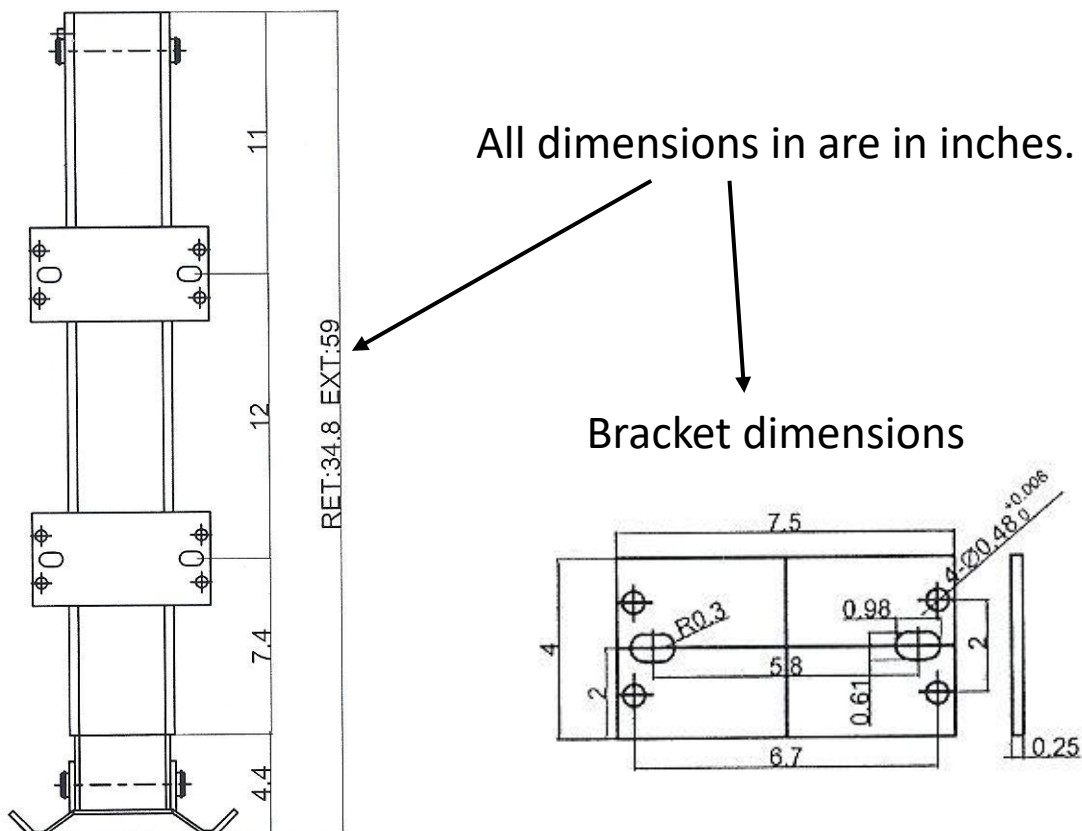

General Information

Up body hose is attached to extend port “raising/extending” of hydraulic jack.

Down body hose is attached to retract port “lowering/retracting” of hydraulic jack

If two jacks being used (in tandem) then the flow divider is strongly recommended between the HPU unit and the jacks

When using with a dump trailer hoist system a diverter valve should be used.

Hoses, flow dividers, HPU’s, etc are available and sold separately.

Several complete suggested hydraulic circuits follow below.

Hydraulic Jack Ports

9/16-18 #6 SAE JIC 37 degree flare fitting retract port

9/16-18 #6 SAE JIC 37 degree flare fitting extend port



Single Hydraulic Jack Application

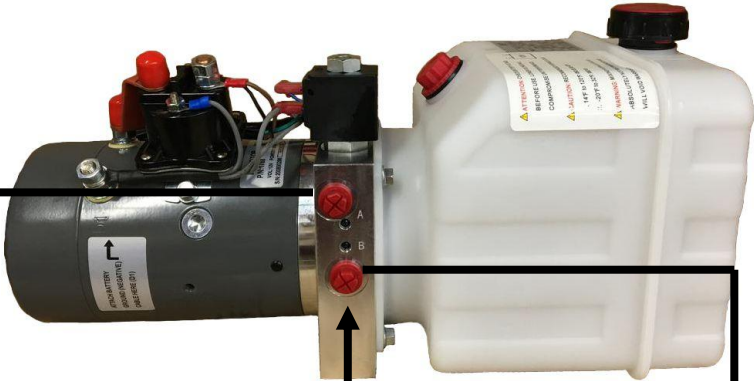

Hydraulic line to run from extend port (lower one) on jack to port A on HPU unit. (Maximum pressure 3200 psi)

RH-FIT38 or RH-FIT38L adaptor fittings between o-ring thread and 37 degree fitting on hose for both port A and B

Hydraulic line to run from retract port (upper one) on jack to port B on HPU unit. (Maximum pressure 1500 psi)



Dual Hydraulic Jack Application

Hydraulic line to run from Port A on HPU unit to the single port side of flow divider (HFD-612)

RH-FIT38 or RH-FIT38L adaptor fittings between o-ring thread and 37 degree fitting on hose for both port A and B

Hydraulic line to run from extend port (lower one) on jack to dual port side of flow divider. (Maximum pressure 3200 psi)

Hydraulic line to run from extend port (lower one) on jack to dual port side of flow divider. (Maximum pressure 3200 psi)

Flow Divider (HFD-612)

RH-FIT38 or RH-FIT38L adaptor fittings between o-ring thread and 37 degree fitting on hose for both port A and B

Hydraulic line to run from port B on HPU unit to t connector fitting (RH-FIT38T). (Maximum pressure 1500 psi)

Hydraulic line to run from retract port (upper one) on jack to t connector fitting. (Maximum pressure 1500 psi)

Hydraulic line to run from retract port (upper one) on jack to t connector fitting. (Maximum pressure 1500 psi)

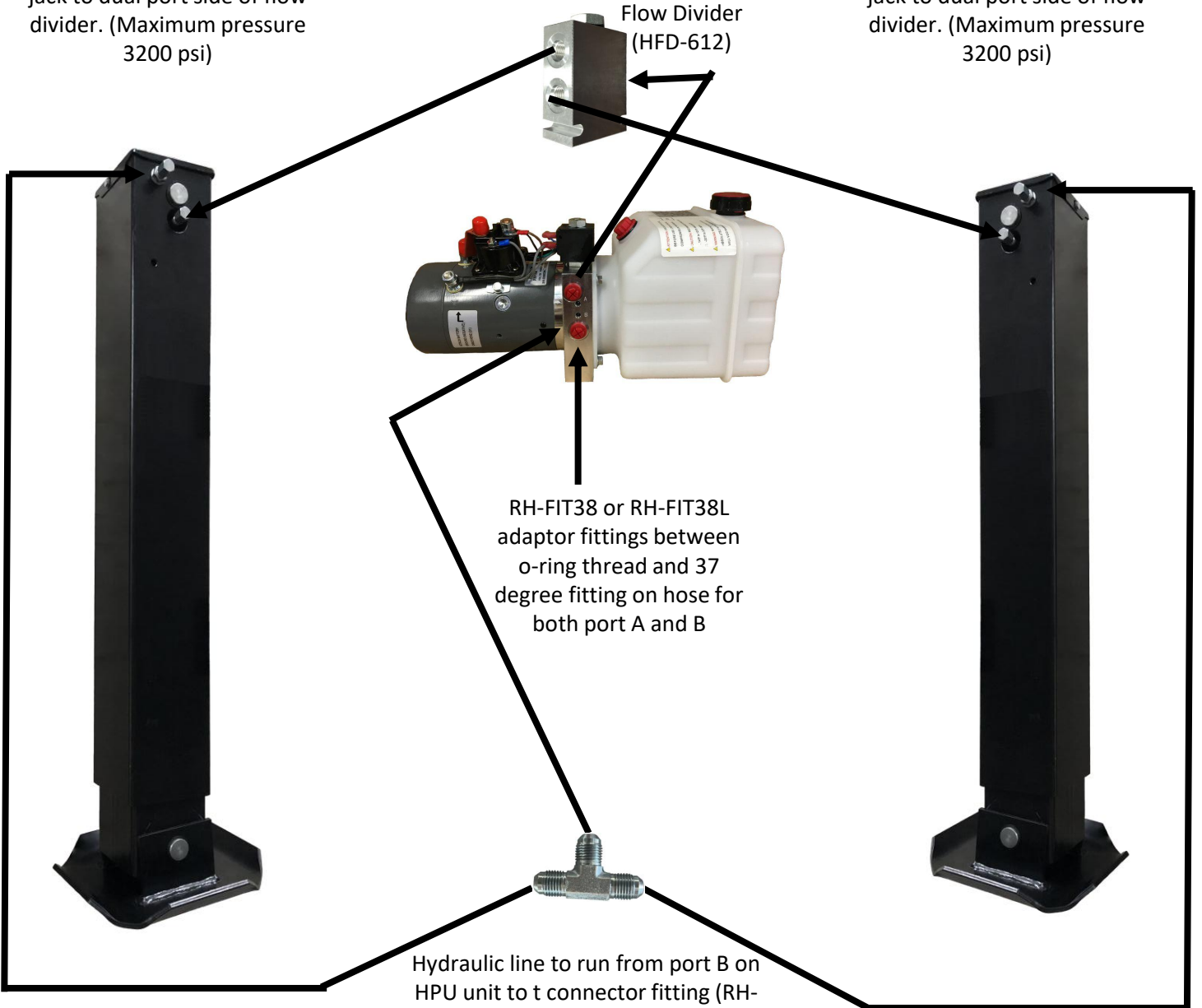

Dual Hydraulic Jack and Hoist Cylinder Application

RH-FIT38 or RH-FIT38L
adaptor fittings between
o-ring thread and 37
degree fitting on hose for
all ports

**In this application, use a six
quart reservoir or greater.**

Hydraulic line to run from port
A on HPU unit to port P of
hydraulic diverter (RH-6WFD).
(Maximum pressure 3200 psi)

Hydraulic line to run from port
B on HPU unit to port T of
hydraulic diverter (RH-6WFD).
(Maximum pressure 1500 psi)

Flow Divider
(HFD-612)

Hydraulic Divider
(RH-6WFD)

Hydraulic cylinder on hoist

T Connect (RH-
FIT38T)

**Between hose and cylinder at
this point use load control valve
(RH-LDCTL)**

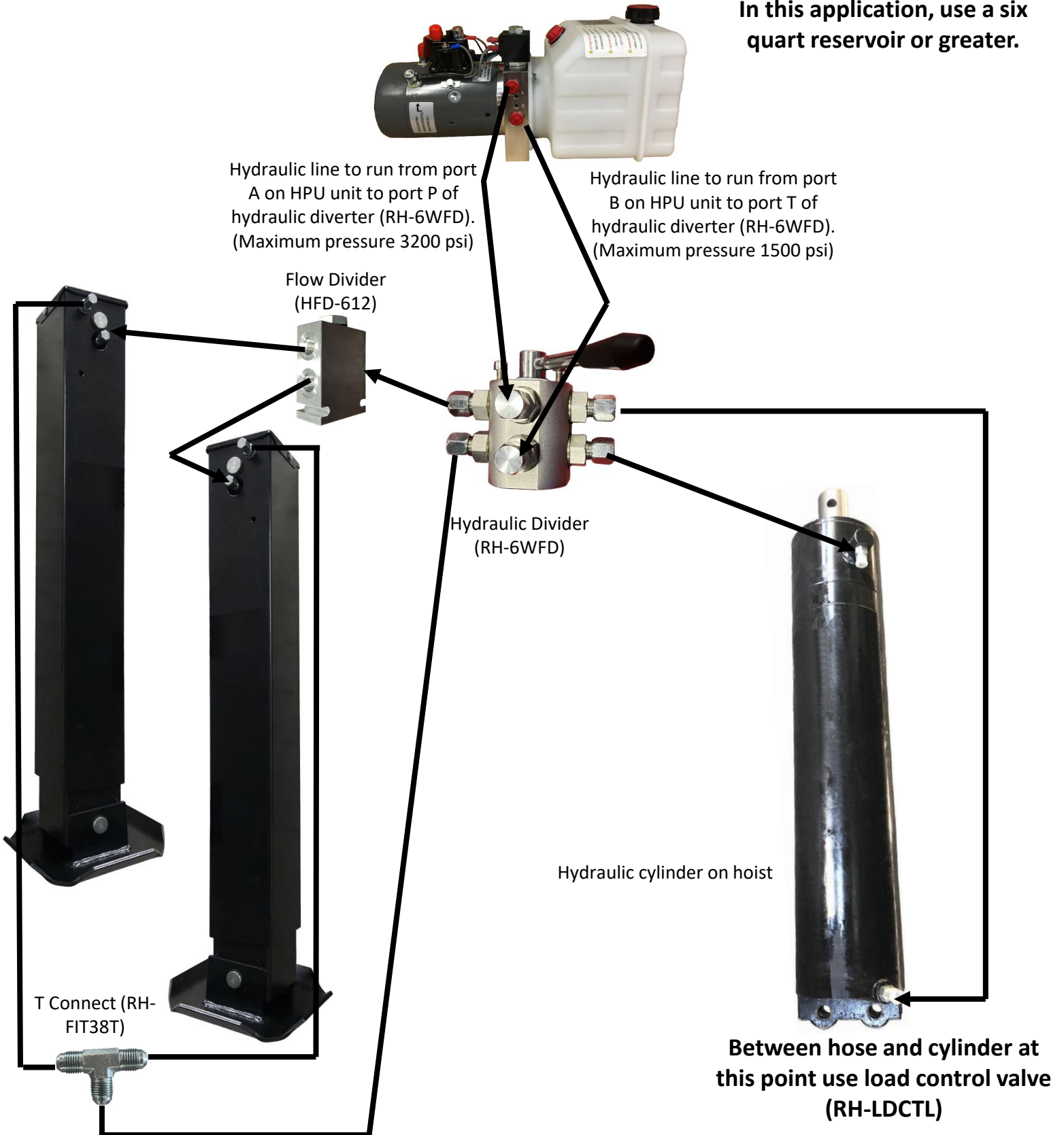

15K Hydraulic Jack Operation and Maintenance

Before operating hydraulic jack, make sure trailer is on a flat/even surface. Make sure that surface is capable of holding the weight of the trailer.

When using jack for the first time, you will need to bleed the hydraulic jack and hoses of any air in the system. Following the bleeding instructions in the (HPU) Hydraulic Power Unit manual.

Do not lubricate tubes on jacks. Lubricant can attract dirt which could affect operation of jack.

Troubleshooting

If jack is not extending or retracting check the following:

- Make sure all electrical connections are secure and battery is fully charged and grounded.
- Make sure hydraulic fluid is flowing from the HPU unit and through the lines. Check to make sure there are no leaks or pinch points in the hoses and all hydraulic connections are secure.
- If jack retracts after leveled to desired location, check fluid level in the HPU unit and that all hydraulic connections are secure.
- Can also refer to Q&A section on our website.
www.ramtrailerproducts.com

HPU / Control Switch – Remote Pendant



- Hydraulic power unit (sold separately) includes control switch / remote pendant
- 3200 psi extension / 1500 psi retraction maximum pressure
- Works with RAM 15K hydraulic jack (HJ-15000-LEG) as well as RAM hydraulic dump trailer hoist systems (RH-310, RH-516 and RH-520)
- HPU-DA004 dual acting, four quarts usable volume
- HPU-DA006 dual acting, six quarts usable volume
- HPU-DA008 dual acting, eight quarts usable volume
- See HPU manual for additional models available
- When using one HPU to power a scissor hoist and two 15K hydraulic jacks use a six quart reservoir or greater.

We recommend using a *RAM* supplied HPU and control switch / remote pendant. See respective *RAM* instructions for setup and operation.

Other Hydraulic Accessories Available - Continued (sold separately)



RH-FIT38 3/8" fitting



RH-FIT38T 3/8" T fitting



RH-FIT38L 3/8" L-shape fitting



RH-LDCTL 3/8" load control valve



RH-6WFD Hydraulic Diverter

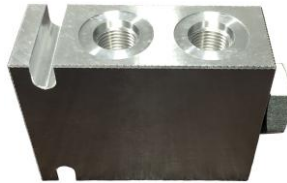

HFD-612 Flow Divider



RH-LHG Heavy duty hinge assembly



RH-MHG Medium duty hinge assembly



RH-LKCL-20 2" locking collar
RH-LKCL-25 2.5" locking collar
RH-LKCL-275 2.75" locking collar



RH-BCBL-20G4 Battery cables, one red, one black, GA 4 20"



RH-STRP rubber battery strap



HCYLND-516 5" diameter x 16" stroke hydraulic cylinder
HCYLND-520 5" diameter x 20" stroke hydraulic cylinder



Dump Trailer Hoist with weld on brackets/pivot bars (less hydraulic cylinder)

RH-310 Hoist Assembly 310 (set up for 3" diameter and 10" stroke cylinder)
RH-516 Hoist Assembly 516 (set up for 5" diameter and 16" stroke cylinder)
RH-520 Hoist Assembly 520 (set up for 5" diameter and 20" stroke cylinder)

Hydraulic Hoist Safety Accessories



Safety arm



Safety arm cup



Safety arm bracket